



Myrtha Technology





Technology and materials

- Smart use of materials 4
- Key components 6
- Installation phases 8
- Models and applications 10
- Special solutions 14

Why choose Myrtha? 16

Water circulation 20

Accessories and additional systems

- Special systems 22
- Competition accessories 26
- Leisure and wellness accessories 28

Applications and projects

- Competition pools 32
- Communities and leisure pools 34
- Hotels and resorts pools 36
- Health and fitness clubs pools 38
- Thermal and SPA pools 40
- Institutional pools 42
- Therapy and rehabilitation pools 44
- Temporary pools 46

Smart use of materials

Myrtha is the most exclusive and advanced technology in the swimming pool industry. It's patented pre-engineered modular system, based on the use of laminated stainless steel panels and buttress system, enables a Myrtha structure to attain per-

fect waterproofing. Myrtha Technology provides the ideal solution to the many limitations of traditional reinforced concrete structures and ordinary prefabricated swimming pools.

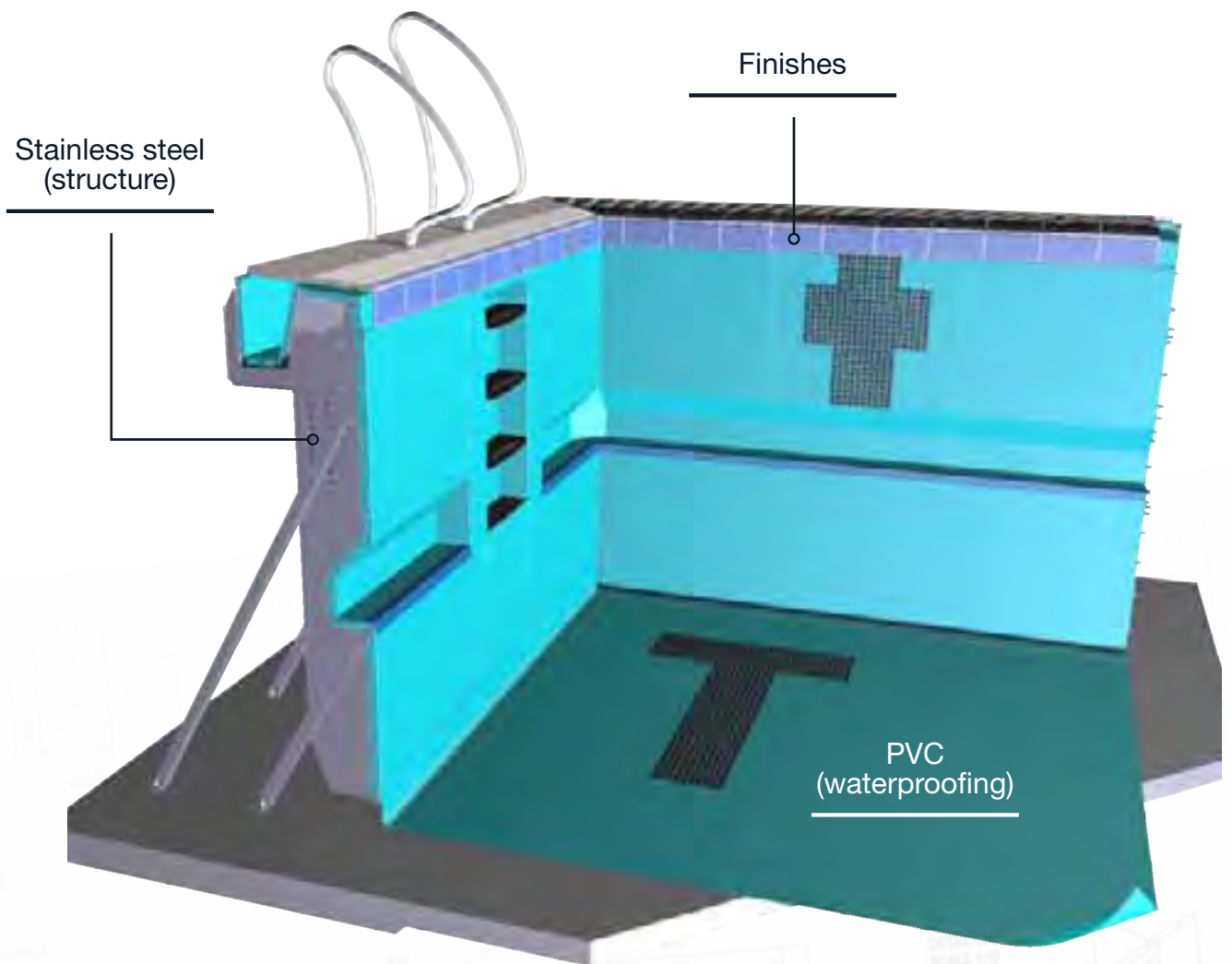

► Stainless steel - structure

High quality stainless steel used in a Myrtha pool guarantees extremely long life to the structure regardless of the presence of highly aggressive soils or high water-tables. Myrtha uses exclusively-engineered components bolted together, thereby eliminating the need for welding, which is subject to increased corrosion. The use of stainless steel materials ensures maximum mechanical strength of the panels, buttresses and the other components that form the structure of the swimming pool.



► PVC - waterproofing

Perfect waterproofing is ensured by the unique process of bonding PVC to the Myrtha steel panels. A hard PVC membrane is hot-laminated to the steel in the manufacturing process. A reinforced PVC membrane is used on the floor of the pool in order to follow the contours of the concrete sub-surface.

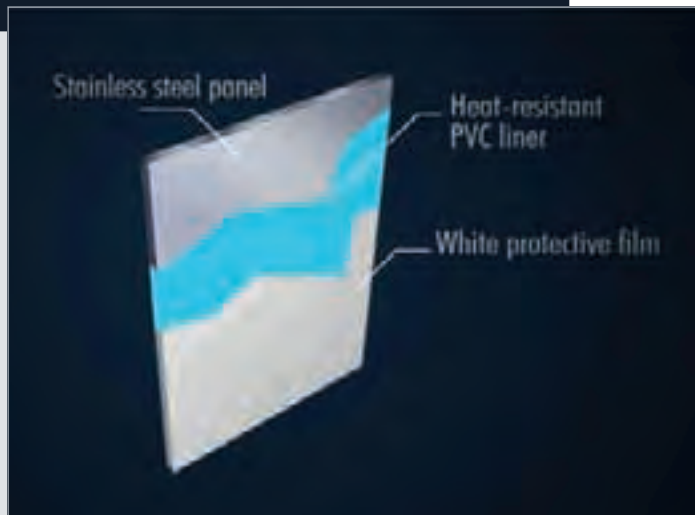

► Finishes

For high level aesthetic finishes, Myrtha technology uses a wide range of exclusive materials that match with the colours of the PVC. Myrtha allows the use of special stone and marble finishes to ensure more elegance at the pool project. This combination of materials and colors allow the client to personalize each and every swimming pool according to their specific needs.



Key components

1

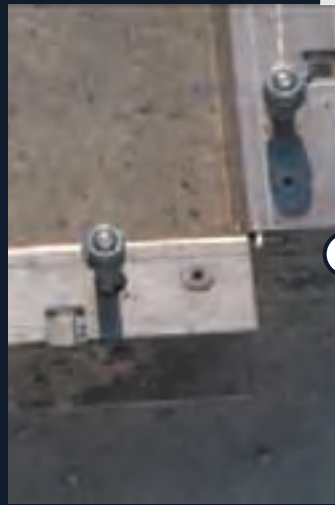

2



3

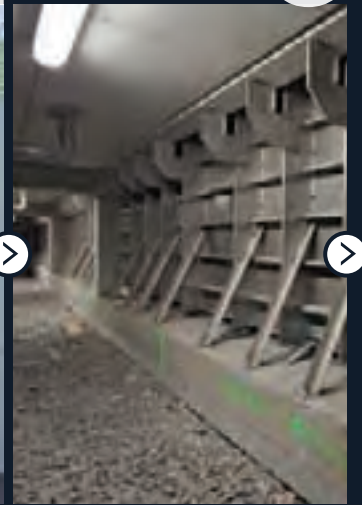

The base frame

The base frame that outlines the swimming pool is constructed of bolted steel sections that form the supporting structure for the Myrtha wall panels. It is mechanically connected firmly to the concrete footing by the use of chemical anchors. Rigidity is obtained by the use of numerous threaded bars (anchor bolts) which are anchored in the perimeter curb. The threaded anchor bolts also provide micrometric adjustment so that perfect leveling of the structure is achieved.

The wall structure

The pool walls are formed by the use of sturdy, prefabricated stainless steel pools panels. They are factory laminated with a permanently welded layer of hard PVC, and are then bolted to the base frame and to each other. Similar to the aviation industry, the use of actual steel welding is avoided, thus there are no potential corrosion points in a Myrtha structure. The exclusive use of stainless steel for the structural components and PVC for waterproofing means that there is minimal risk of corrosion with a high probability of leak-free construction.

The support buttresses

At vertical panel joint (3 feet), sturdy steel buttresses provide rigidity and strength to the structure. Each buttress is anchored to the concrete footing. The structure is both sturdy and elastic and is therefore ideal for installations with difficult ground conditions (e.g. seismic zones, or on unstable soils).

4



The overflow gutter

The Myrtha overflow gutter is made with the same material that is used for the wall panels and comes in a wide range of standard configurations. The gutter can be supplied with a design ("diagonal flow") which limits the evaporation of chemicals and reduces the noise of the falling water. The patented Myrtha gutter grating has been designed to meet the strictest anti-slip and load requirements and the gutter dropouts can be supplied with silencers which virtually eliminate noise.

5

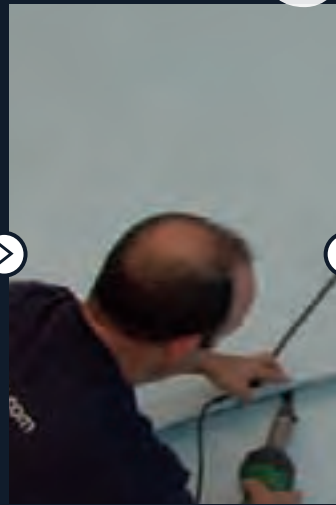

Floor reinforced membrane

The standard floor of a Myrtha pool is formed using a concrete slab, which needs only to provide a smooth support surface. The slab is waterproofed by a reinforced PVC membrane, produced specifically for use with swimming pools and protected with a surface lacquering. Myrtha pools can be built without concrete as the sturdiness of the stainless steel structure is assured through the engineered footings. A special matting has been developed by Myrtha Pools to attain a smooth support surface for the membrane, whilst at the same time allowing subsurface drainage. In any type of Myrtha pool, this floor can be supplied with a user-friendly "Softwalk" floor.

6

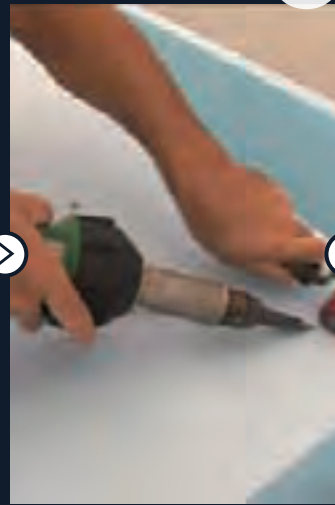

Fittings

In order to allow for better waterproofing all joints between the Myrtha sections are welded with a liquid PVC or a reinforced PVC tape. The result joint is extremely resistant, optically uniform to the panel surface and aesthetically pleasant.

7

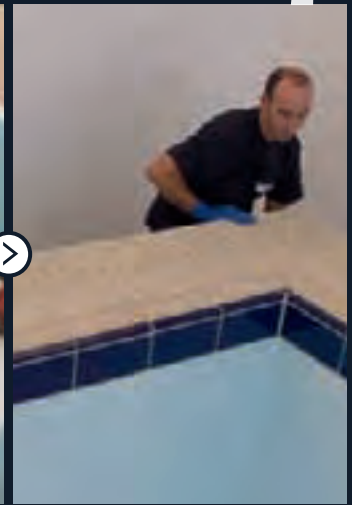

Finishing

After the pool has been completely sealed and the overflow gutter installed, the ceramic tiles are applied onto the Myrtha surface. Gluing tile on a Myrtha stainless steel surface is much easier and safer than on concrete. As there is no possibility of water seepage from behind the tile, the traditional problem of poor long term adhesion is therefore eliminated.

Installation phases

1

Levelling

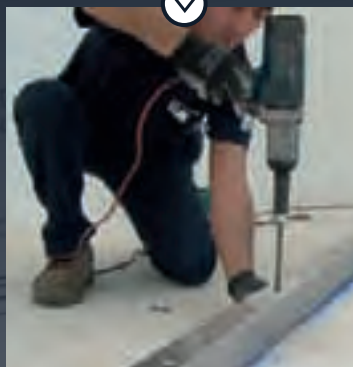
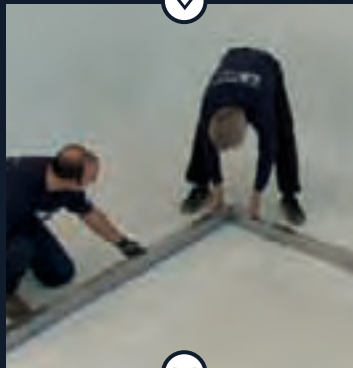
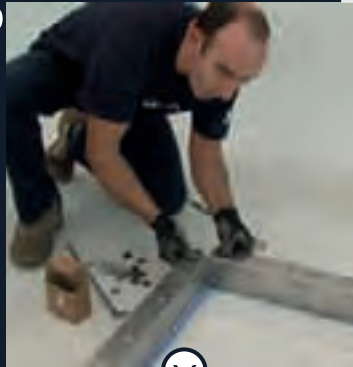

2

Wall construction

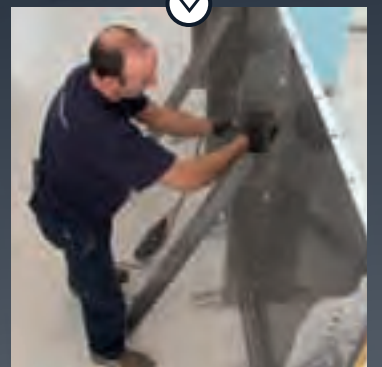
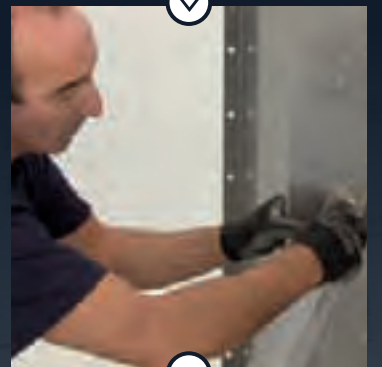
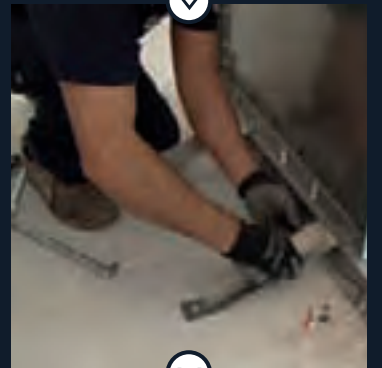
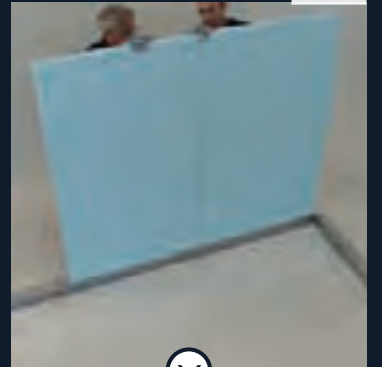

Overflow gutter

3

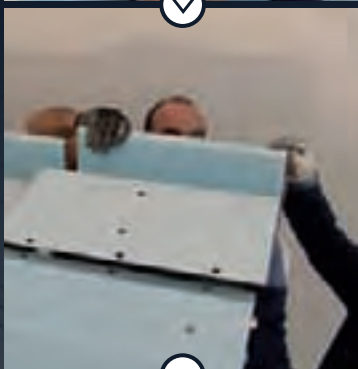
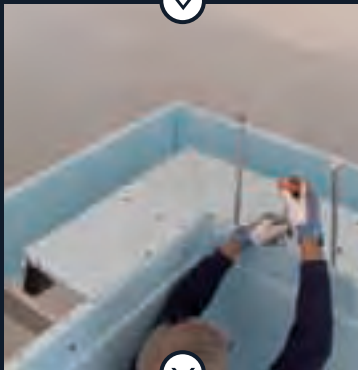
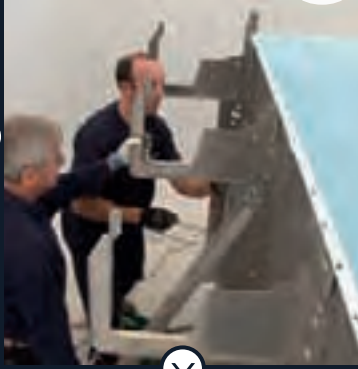

Waterproofing

4

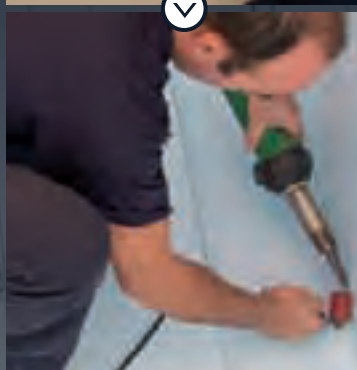
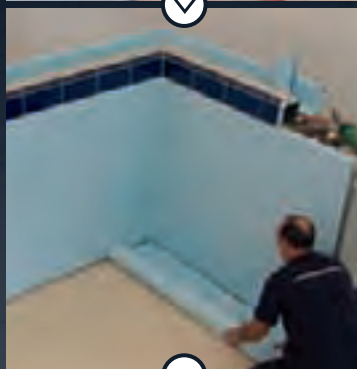

Finishes

5

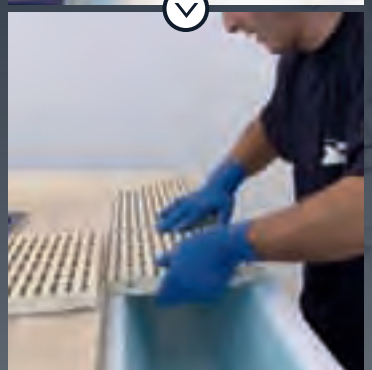
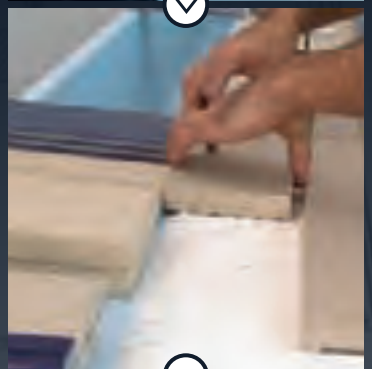
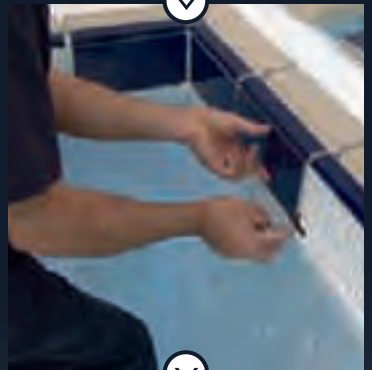
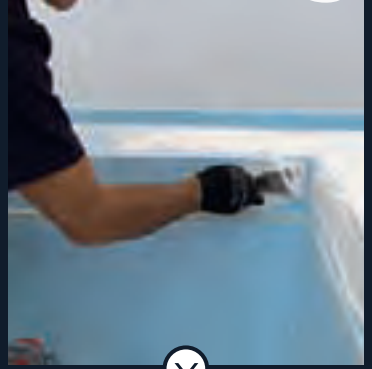

Models and applications

► Skimmer

The traditional Skimmer version, which presents the water level lower than the floor level, has a ceramic finishing that enriches the visible part of the pool and helps cleaning operations. This system is ideal for public pools with reduced dimensions.

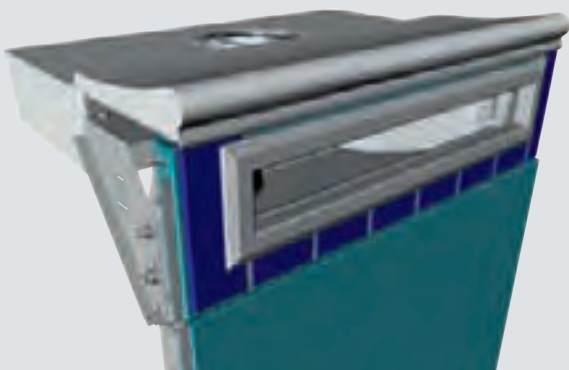

► Overflow Gutter | Classic

Myrtha Classic Overflow is ideal for all the pools that guarantee an excellent water recycle with reduced dimensions and still maintain an aesthetically uniform mirroring surface. It is completed with a simple but pleasant PVC finishing on the highest part of the panel.

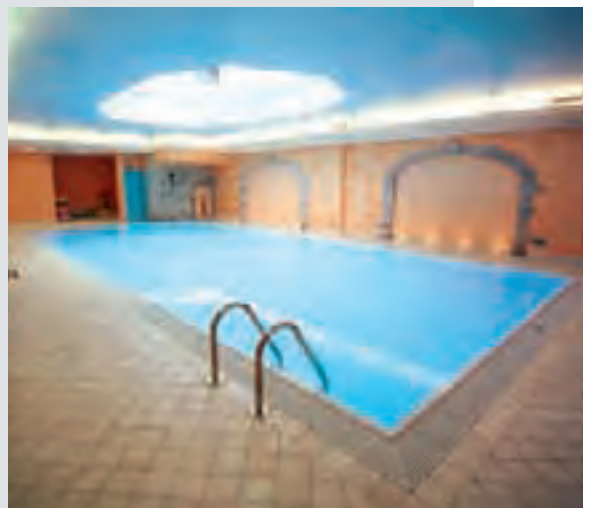
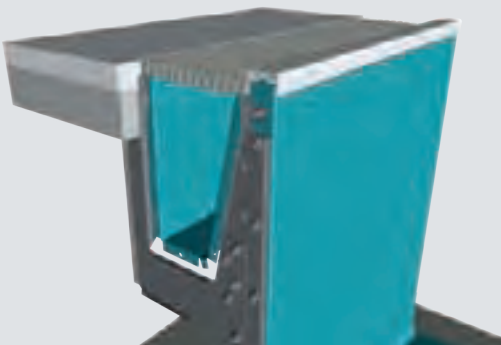

► Overflow Gutter | Classic Competition

The Classic structure is ideal for big competition pools, as the PVC copying is flashed with wall panels, either on all the perimeter of the pool or only on the two short sides. This technology is also the most suitable for the renovation of pools that need to meet international regulations.



► Overflow Gutter | Ceramic / 1

For public pools usually used for training sessions – schools, fitness centres and sports centres in general – Myrtha Ceramic1 is the most used and appreciated technology. Its ceramic tile places the overflow gutter slightly moved from the boarder so that the wave produced by the swimmer is better absorbed and does not reduce the swimmer's pace.

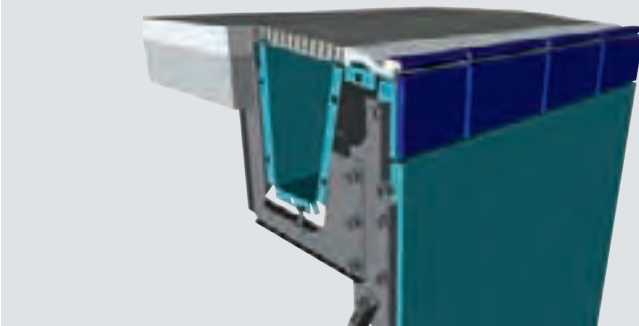

► Overflow Gutter | Ceramic / 2

Myrtha Ceramic 2 presents two ceramic tiles that move even further the overflow gutter and guarantee the maximum absorbing coefficient of the wave impact during training lessons or competition events: the most suitable technology for completion implants.

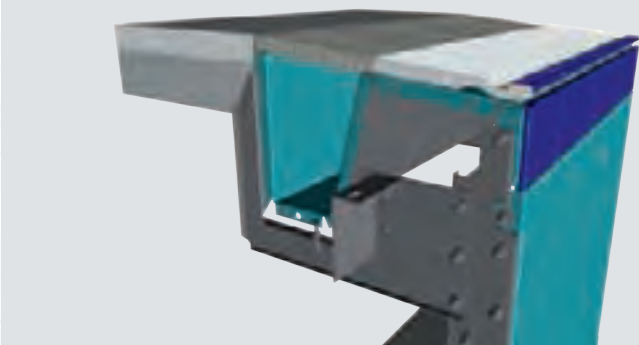

► Overflow Gutter | Structural

Myrtha Structural Overflow Technology is characterized by a special Klinker ceramic tile that functions as part of the actual structure of the wall panels. This structure guarantees a perfect overflow level while maintaining an attractive finish, in fact it can be considered the ideal technology for public leisure pools with any design.

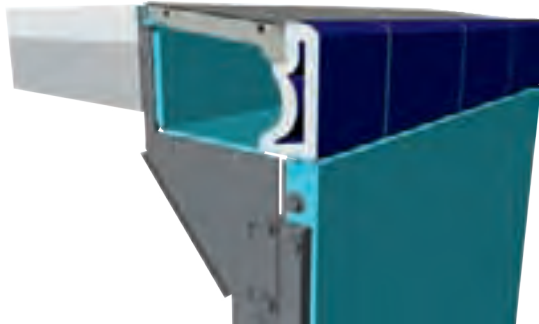

► Recessed overflow gutter

The brand new overflow gutter finishing solution as an alternative to the standard ABS grid. Special edge elements, specifically designed for swimming pools use, can be placed and fixed to the overflow gutter, perfectly allowing the water flow and providing a smart finishing to the pool. Different materials and surfaces, highly durable and with high tech performance, can be chosen for both the deck and the edge of the pool: marbels, stones, wood and porcelain stonewares, inspired from natural and precious materials.

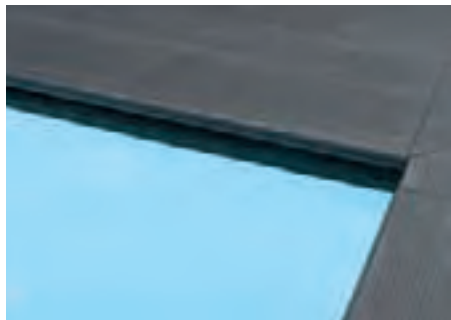
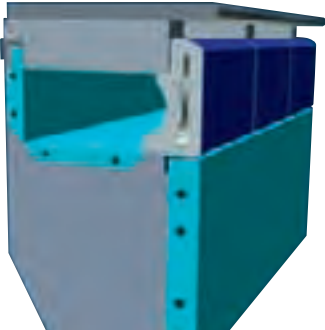

► Vanishing Edge | Ceramic / 1

Ceramic/1 structure can also have a vanishing edge effect that guarantees the best success on hills or particular surroundings. Generally it is utilized on one side of the pool with a ceramic tile that follows the external side of the pool and ends directly in the overflow gutter.

This technology can be an elegant and efficient solution for public leisure pools, especially in condominiums or accommodation facilities.

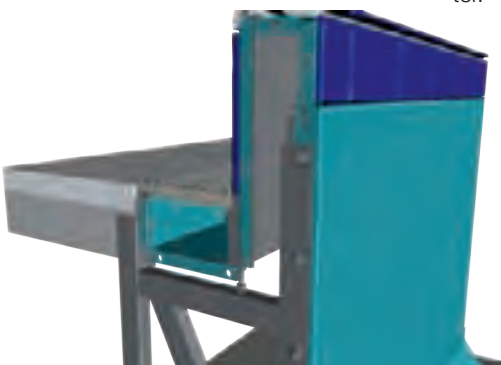

► Vanishing Edge | Structural

The Overflow Structural technology has evolved from the Ceramic1 Vanishing edge technology. Above the Myrtha panels a ceramic tiles functions as part of the structure while still creating a gentle slop that fades away in the gutter.

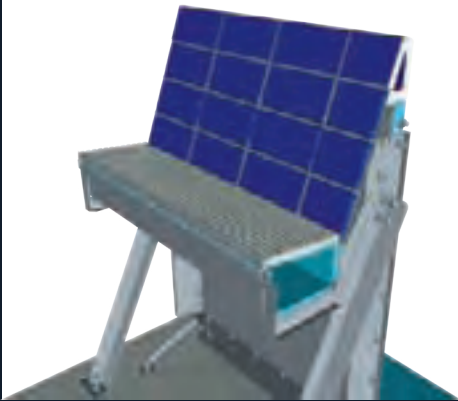

► Headwalls

To comply with F.I.N.A. regulations for competition pools that do not have an overflow structure on all four sides a headwall is required at 30cm above the water level, often completed by ceramic tiles that guarantee simple cleaning and satisfies the eye.

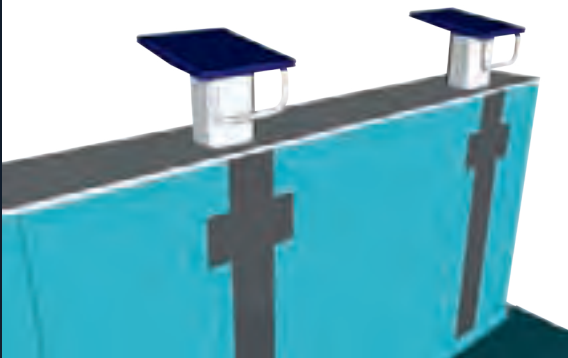

► Combined Technologies

All the technologies described above can be combined to meet design requirements: competition pools combine overflow technologies with headwalls; public and leisure pools combine skimmer systems with one or more vanishing edge or headwall system too. Myrtha Pools can offer the work of a specialized technical staff who continuously search for the best solutions to advise the client according to need and surrounding.

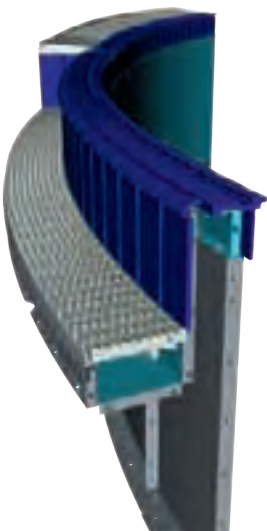

Special solutions

► Finger Wall



This solution is an additional structure raised above the level of water that can be used as a dividing wall between different areas of one big pool or as a relax area for swimmers. It is generally covered by ceramic tiles and meets the finishing solutions of the rest of the pool.

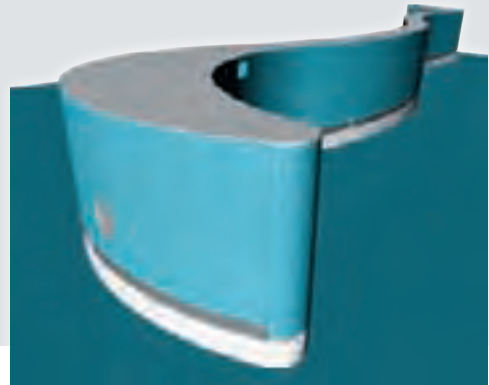

► Zero Entry



Otherwise known as “beach entry”, is a walk-in option commonly associated to leisure pools but available for all projects. It integrates an anti-slip surface as well as a “soft floor” underlayment to further enhance the beach effect and provide an added safety aspect created with our Softwalk solution.



► Islands and Rivers



From the Crazy River to the Lazy River, amusing or relaxing, fast or slow flow, Myrtha does it all! Rivers and islands can be inserted for aesthetic reasons, for fun or even for the functionality of the structure.

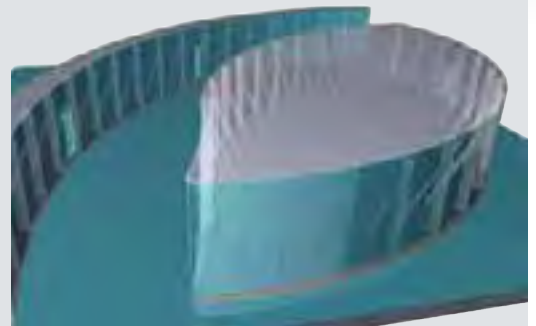

► Double level



Double level is often inserted for an aesthetic purpose to allow for a waterfall effect, but it can also be functional for the architecture of the pool or for the surrounding floor.

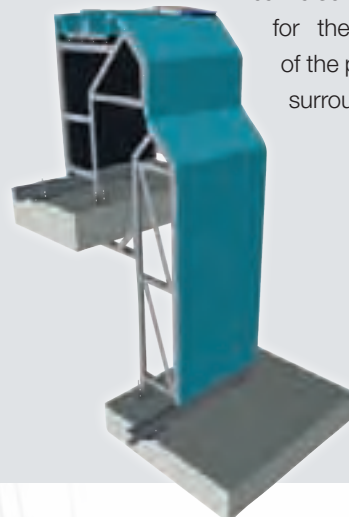

Why choose Myrtha?



Company experience and knowledge

A 50 year experience that guarantees the realization of 1500 pools per year with 300 for public use; more than 50 installations for International Swimming Events and references in over 60 Countries. Myrtha Pools can boast an advanced technical department with a direct transmission of the manufacturing drawing to production; a Research & Development team for laboratory tests; and installation groups trained during professional seminars by Pool Academy; the same Company responsible for the total package.

Advanced engineering-quality control

Myrtha pools can be built in a very short time, thanks to their pre-engineered design. The components are manufactured according to ISO 9001 standards by automated machines and shipped directly to the building site. This facilitates a timely installation process that does not require the use of heavy equipment and which reduces significantly the risk of assembly mistakes on the construction site.





Micrometric precision

A comprehensive design developed with CAD and 3D design software that allows for a check of eventual structural overlapping and a control of the overall supply completeness. The tridimensional overall assembly generates a customized industrial manufacturing process and an automatic quantity control for an automatic material list with no mistakes. Myrtha pools micrometric precision comply with FINA regulations and competition facilities rules.

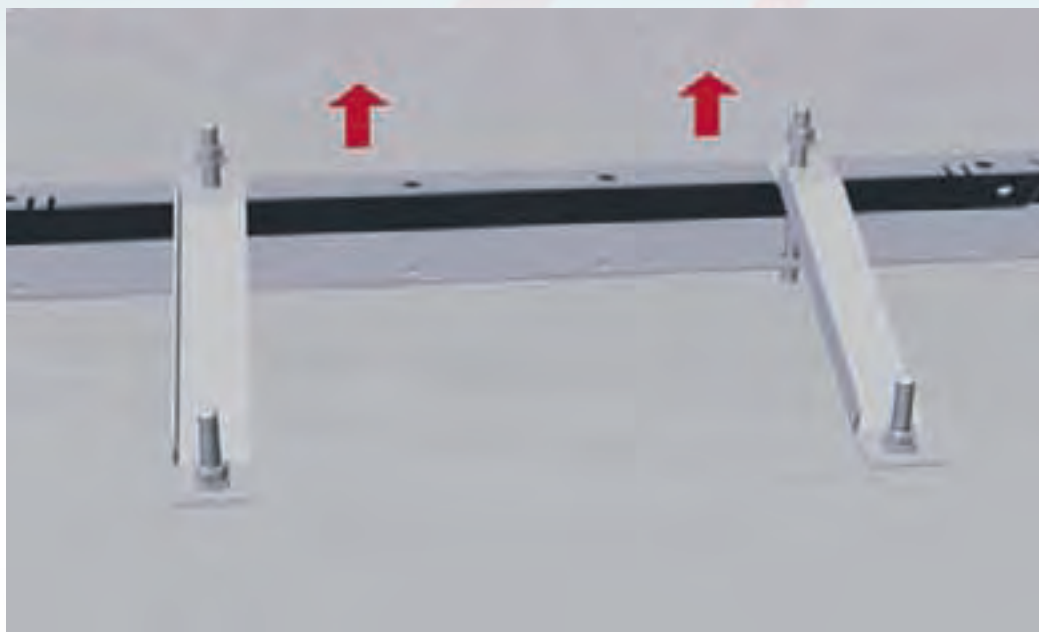

Any size, any shape, any depth

The Myrtha technology is adaptable to fit every type of pool project. Myrtha is suitable for both precise competitive situations as well as the most elaborate freeform pool design.

Low maintenance, easy to clean and care for

Unlike traditional constructions, Myrtha pools do not require a significant maintenance schedule. Sturdy, built to last, and not subject to dimensional variations, a Myrtha structure will not suffer cracks or be susceptible to leaks and is not affected by the aggressive action of chlorinated pool water.



Long life and extensive guarantee

Swimming pools built using Myrtha Technology have a virtually unlimited life, thanks to the structural integrity and proven characteristics of the materials used and to the advanced technological features of a modular system. This is why Myrtha can confidently warranty its pools for many years.

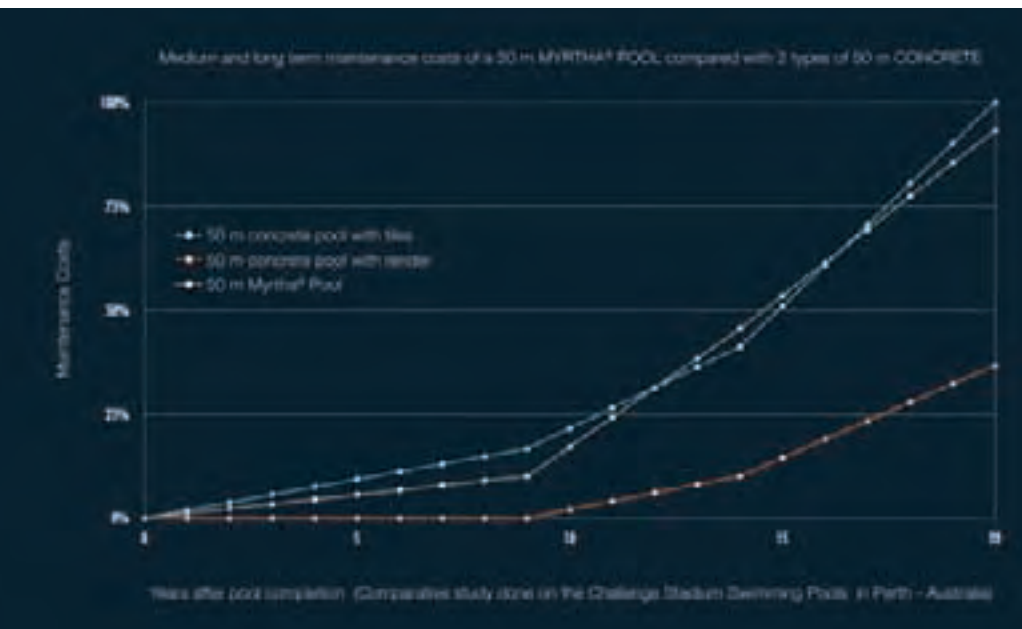

High level finishes

Myrtha offers a wide range of finish details to suit the most discerning architect or client. All of the materials used are of the highest quality.





Suitable for the most difficult situations

Thanks to the advantages of a light, sturdy and easily-adaptable structure, it is possible to build Myrtha pools in the most difficult of environments: above ground in high rise buildings, in small inaccessible spaces, on unstable soils or in areas with high water tables; in seismic zones and in the widest range of climatic and geological conditions.

Environmental friendly

Whit most Governments recommending the reduction of CO₂ emissions, Myrtha Pools commissioned ACOR Consultant to calculate the energy used in building a Myrtha pool. The Carbon footprint of Myrtha (the quantity of CO₂) is significantly lower by 50% compared to a traditional pool made with concrete and tiles: Myrtha could provide heat to a 100sqm apartment for at least 45 years!

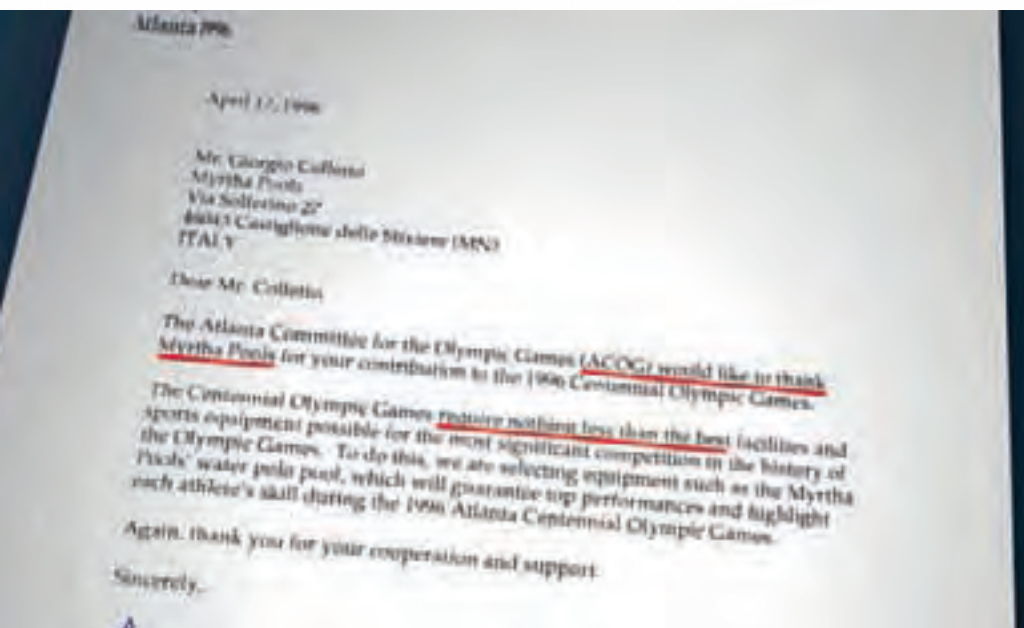

Satisfied customers

Myrtha Pools can boast many satisfied customers among the organizational committees of sports events in which Myrtha Technology has been used.

Water circulation

A good pool project shall also take into consideration issues as the high water quality, the physical safety of swimmers, the expected users load and the regulatory requirements.

Myrtha swimming pools are designed basing on these criteria, both considering the needs of public health and easy maintenance of the pool.

Myrtha pools has invested also in this fields of research, by developing specific studies on recirculation systems preliminary analysis, as well as new solutions for water circulation.

► Traditional distribution



Use of inlets on the pool floor allows for an uniform distribution, complying to local regulations.



► Strahlenturbulenz



It represents nowadays an evolution of traditional water circulation system and the most efficient solution.

Based on the Venturi effect with controlled turbulence, it reduces risks by avoiding piping in the pool floor.

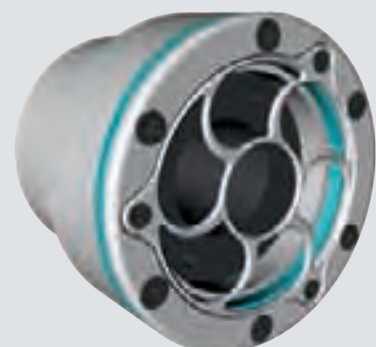

► 3D simulations

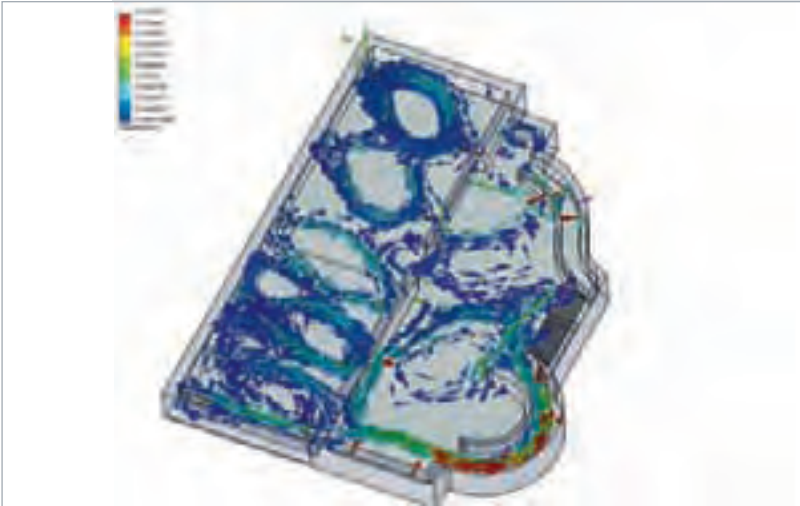

2D and 3D CFD simulations applied to a pool can provide essential information about the circulation: digital dye test, verification and optimization of circulation, as well as development of special features and accessories.

The picture on the left shows a digital dye test after 15 minutes for 3 different depths shows eriochrome concentration.

► Hydraulic calculations and test

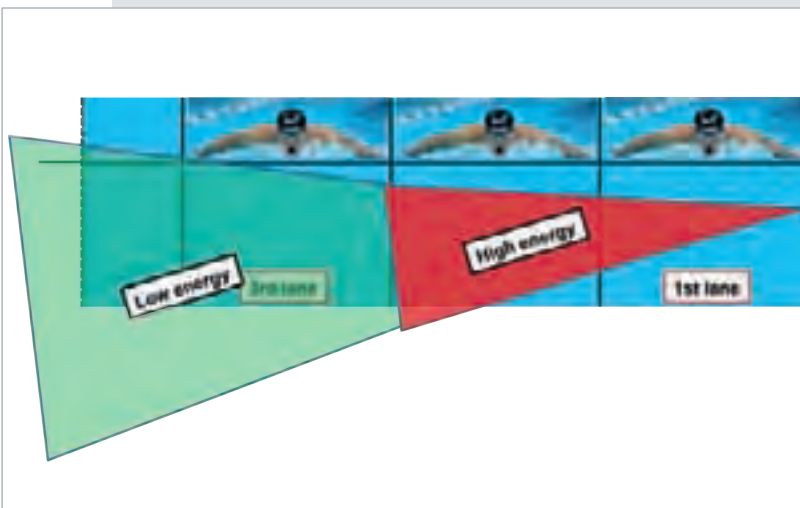

Myrtha Pools started improving CFD in order to exactly perform the calculations required and to simulate the interaction of liquids in a swimming pool.

Basing on the use of special softwares, Myrtha CFD technology can simulate the pool circulation before its construction, providing reliable 3D simulations and digital tests, as well as analysis of the inlet systems and precise calculations of the dropouts and all the overflow system.

► Specific Myrtha fittings



Made to ensure a perfect fitting and waterproofing on the Myrtha structure.

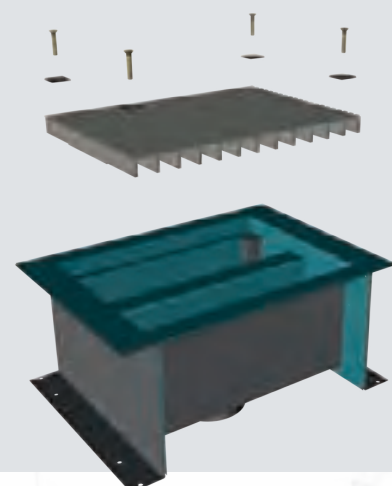

Special systems

► Bulkhead



It separates the pool in different areas, moving along rails installed on the pool deck, thanks to a patented easy movement system. It includes anchors for starting blocks and it can be provided with optionals as footrest step, handrails, floating lane ropes.



► Bulkhead flow-through



Flow through bulkhead allows a large amount of the swimmer surge wave to pass through the bulkhead above and below the water further eliminating the rebound wave and turbulence.

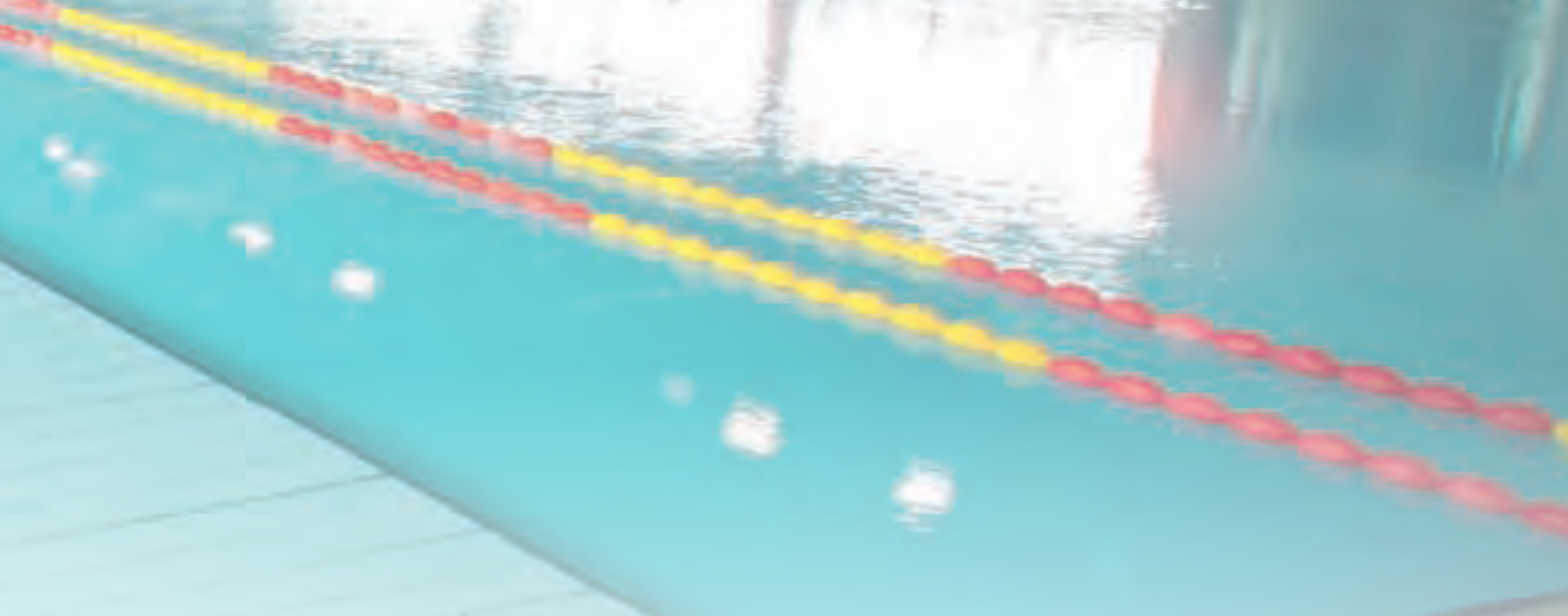

► Floating movable floor

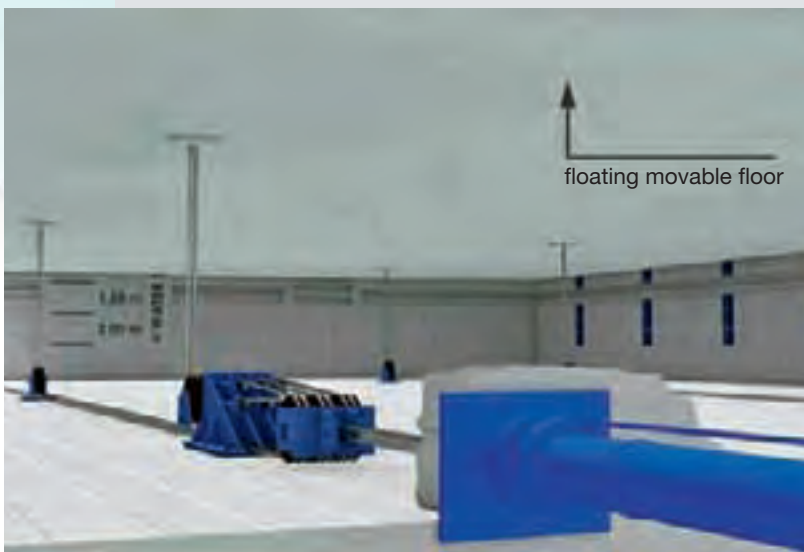

It allows the depth of the pool to be varied, providing a multifunctional use of the pool. Floating structure anchored to the floor through a system of steel cables.

An actuating mechanism outside the pool allows the cables positioning and the movable floor fixing into the desired placement.



► Movable floor with wall movement



This non-floating system is operated by pairs of screw-jacks installed in the pool walls, which allow the upwards and downwards movement of the floor.



► Removable headwalls



Provide pools with overflow gutter on four sides with a 30 cm headwall, as per FINA regulations requirement.

It is also an ideal support for timing touch pads, starting blocks and floating lane anchors.

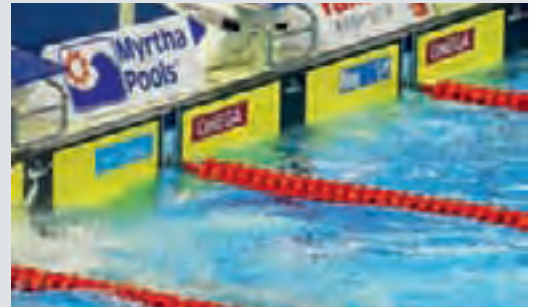

► Air safety cushion



It reduces the diver's impact, by producing a uniform mixture of water and air in the area where the diver enters the pool.

Spargers, positioned under the diving board, provide adjustable bubbling volume and intensity.

► Virtual Trainer



LED stripes system used to monitor the performances of swimmers during training sessions. The system contains a number of preinstalled training programmes and it can be operated by a wireless system.

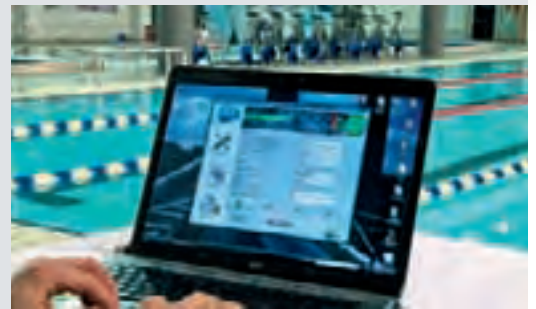

► Waterpolo Visual System

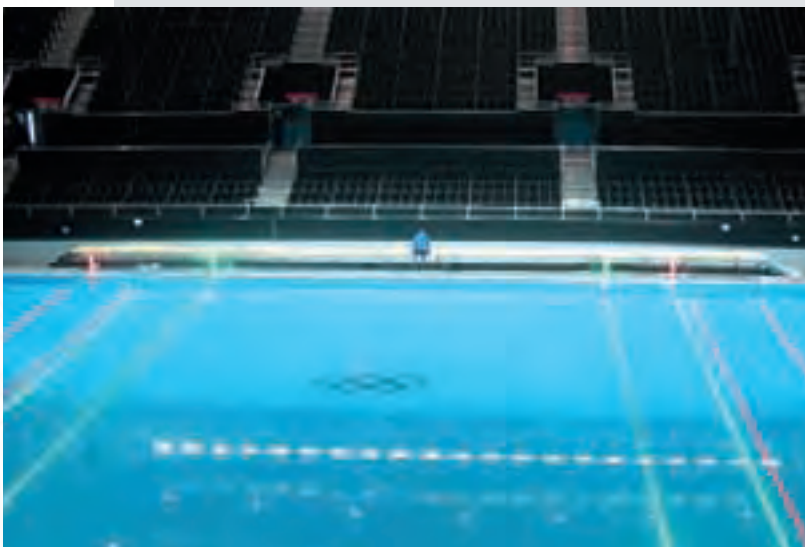

FINA approved system, based on the use of LED markings, placed in specific areas inside and outside the pool.

It allows athletes, referees, judges and spectators to be updated on the progress of the game.



Competition accessories

► Starting blocks



FINA approved. Omega top for TRACK-START can be integrated.

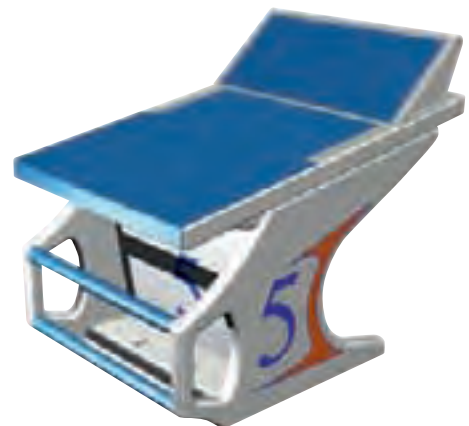

► Lane markings and targets

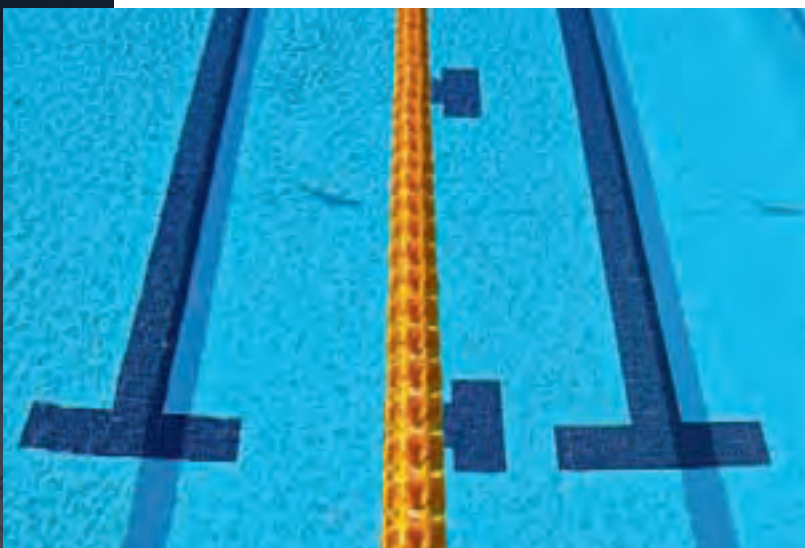

Ceramic Lane markings and targets.



► Lane anchors

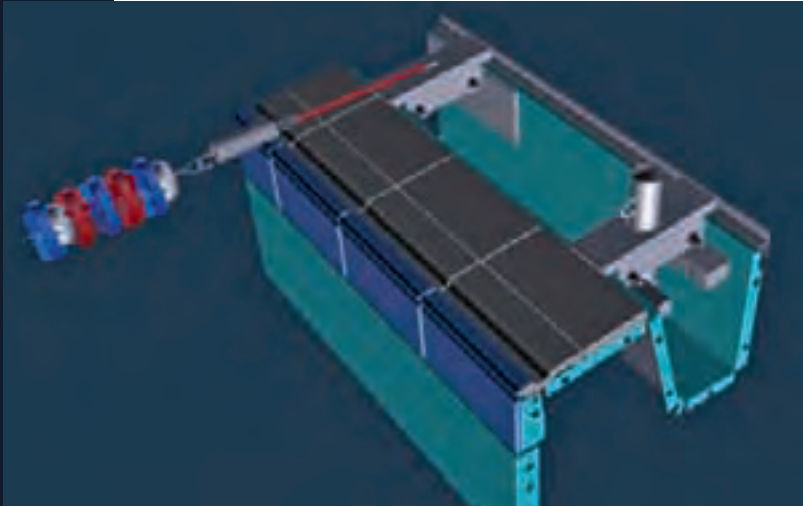

Different types of stainless steel anchors for floating lanes, embedded in the overflow channel to avoid any perforation of the deck.

► Recessed stairs



Preassembled stair on Myrtha panel, it allows for an easy access without reducing spaces.



► Myrtha backstroke system



New footrest prototype, developed in cooperation with Omega, designed to facilitate the departure of backstroke athletes during competitions. The footrest provides a stable support for the athlete on the wall for the feet and allows a faster and more safely push, without the risk of slipping.

Leisure and wellness accessories

► Fountains and geysers



Can be integrated in the floor, in the walls and in the Myrtha gutter.



► Hydromassage stairs



The new hydromassage stairs by Myrtha Pools ensure comfortable and effective air distribution, avoiding concrete works into the pool. Built using special ABS components, they are available in different design and colours alternatives, also with LED back-light possibility.



► Hydromassage benches and air lounges

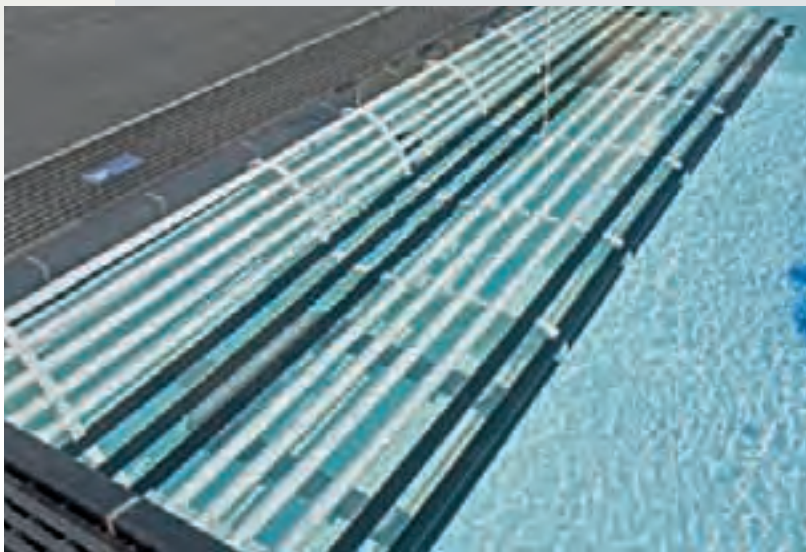

Different technologies available:

1. Tubular structure fixed on the wall
2. Fibreglass structure and ABS slats
3. Concrete lined with membrane and PEM



► New hydromassage air lounges

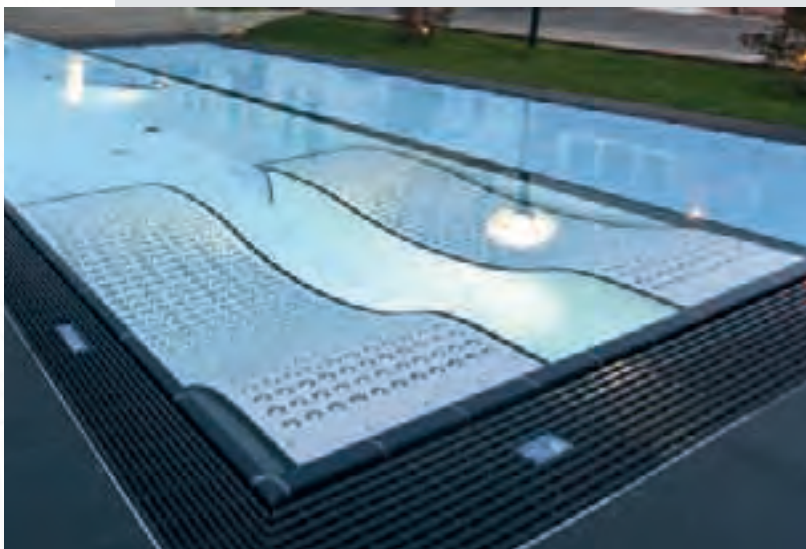

A brand new hydromassage air lounge, designed and produced by Myrtha Pools, in order to provide both comfort and elegance. New Myrtha air lounges are built using special PVC ergonomic plates. Underneath the air lounge surface, a PVC tubes system provides the air massage, operated by a remote control.

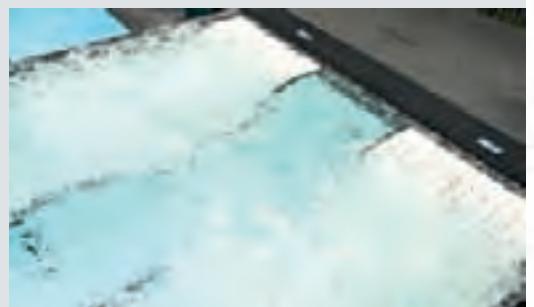

► Accent lighting



Traditional or LED lighting to produce a spectacular or pleasing effect.

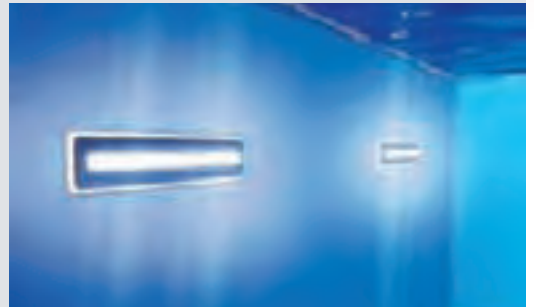

► Rivers



Different types of RIVER JETS integrated in the walls.

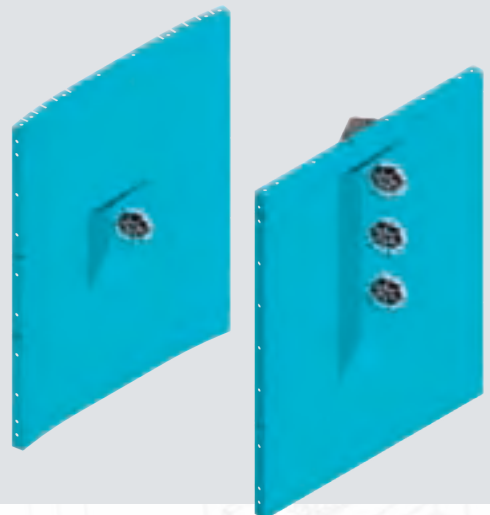

► Hydromassage recessed panel



New hydromassage recessed system, with different jets providing a mixed water and air flow. The hydromassage is operated through a control panel embedded in the pool deck.



► Softwalk - Safety floor

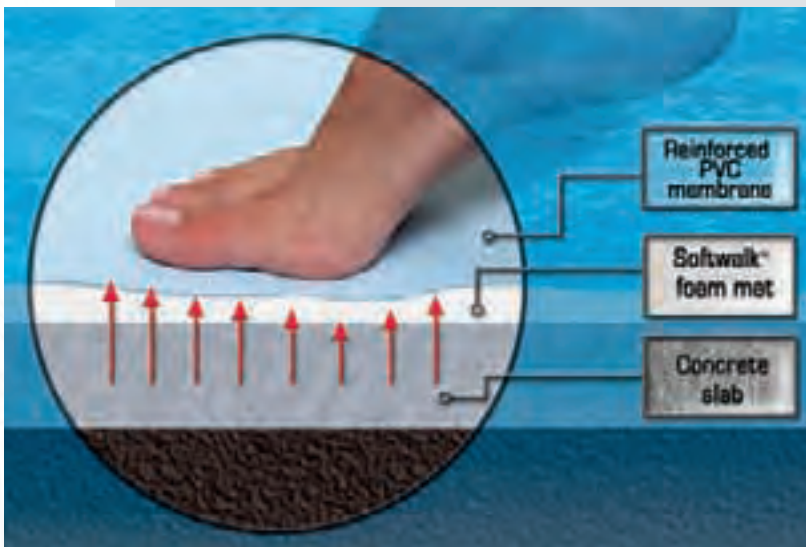

Glued on the concrete basement and covered with PVC membrane, it increases both comfort and security in the pool. It allows for a better protection of the membrane in case of vandalism or accidents.



Competition pools



South Australian Center, Marion (Australia)

Myrtha Pools has structured and perfected their exclusive technologies, specializing in solutions to measure for the realization of big competition systems fast pools: swimming pools, pools for water polo, synchro-swimming, diving pools. The ability to ensure a precise and fast pools installation is very important in the construction of competition pools. That's why Myrtha technology has been chosen by Swimming Federations throughout the world for

some of their most important competitions.

The World Championships in Rome (1994), Perth (1998), Barcelona (2003), Montreal (2005), again Rome (2009), Shanghai (2001), the Olympic Games in Atlanta in 1996, Beijing (2008), London (2012). Myrtha Pools has been also been the pool of choice for the FISU Games, European Championships, USA Olympic Trials, USA Swimming as well as regional Games.

*Aquaniene Rowing Club,
Rome (Italy)*

Three Myrtha swimming pools, an outdoor 53 x 25 m competition pool and two indoor 25 m pools, built on the occasion of the 13th World Championships Rome 2009.



*Kantrida Swimming Complex,
Rijeka (Croatia)*

Three Myrtha pools have been built in the Center: a 53 m competition pool, that hosted the 12th European Short Course Swimming Championships, a 25x10 m warm-up pool and a 10x5 m pool partially built with RenovAction Technology.



*Kremlin-Bicêtre Sports Complex,
Val de Marne (France)*

A 50x20 m historical competition pool refurbished using Renovaction technology.



*Melbourne Sports and Aquatic Center,
Melbourne (Australia)*

The biggest and most modern Australian sport centre has a 52 m outdoor competition Myrtha pool, that hosted many International competitions, as 2006 Commonwealth Games and 2007 XII FINA World Championship.



Communities and leisure pools



Ciudad Deportiva "Espartales", Madrid (Spain)

Myrtha technology and design collaborate in the most imaginative ways when it comes to municipal projects. Myrtha takes special care to integrate the unique culture of each community into every project's vision and the wide array of accessories ensures a pool that's one of a kind. The adaptability of a Myrtha pool suits all requirements found in both public and commercial use and is currently the most breakthrough technology in the market.

Consequently, Myrtha delivers pools that consistently and successfully bring neighborhoods together. Because of its versatility and the possibility of integrating all types of accessories and water features, Myrtha Technology offers a wide choice of options for any part of the leisure pools, indoor or outdoor. Also, the low maintenance of a Myrtha pool guarantees to keep costs down for years to come.

Hawaii Kroc Center, Hawaii (USA)

Thanks to a donation of 1,5 billion dollars given in 2003 to the Salvation Army from the widow of Mr. **McDonald**, a series of state-of-the-art Salvation Army Ray and Joan Kroc Corps Community Centers has been built nationwide. The main goal was to create centres intended for children and families that otherwise have no chance to access public services such as sport centres, theatres and all forms of recreational areas. Thirty-one centres around U.S.A. are expected to be built. In most of these projects **Myrtha Technology** has been chosen for the construction of the pools.



Centre Aquatique Lilo, Miribel (France)

Seven Myrtha pools, 3 outdoor and 4 indoor, sport and leisure facilities all finished with black ceramic tiles, combined with white PVC of Myrtha panels.



McDonald Island Park, Fort McMurray, Alberta (Canada)

MacDonald Island Park Corporation, a not-for-profit company which operates MacDonald Island Park in Fort McMurray's City Centre, is Canada's largest community recreational, leisure, and social centre. Inside the Park, Myrtha Pools has built a freeform leisure pool and a splash pad.



Queenstown Aquatic Center, Queenstown (New Zealand)

All aquatics facilities inside the Center have been provided and installed by Myrtha Pools. A 25 m lap pool, a learners' pool, a wide freeform leisure pool, a lazy river, a toddlers' pool and a SPA pool.



Hotels and resort pools



Grand Hotel Central, Barcelona (Spain)

Myrtha Pools' patented technology guarantees the very best pools for the finest Hotels, Resorts and High Rise facilities around the world. Myrtha Technology is designed to adapt to the challenges of pool construction in varied climates, small spaces and high rise buildings. Myrtha Technology is designed to adapt to the challenges of pool construction in

varied climates, small spaces and high rise buildings. Once installed, a Myrtha Pool does not require the expensive maintenance that traditional pools need every few years thus reducing the amount of scarce resources spent on capital expenditures. Aesthetically, Myrtha Pools have a wide range of accessories to fit the unique profile of hotels and resorts.

*Federation Tower Hotel,
Moscow (Russia)*

At the last floor of the Western tower, inside the Grand Hyatt Hotel, Myrtha Pools has installed the refined pool with white lining and mosaic, underwater lights, hydromassage inlets and swim jets to be used by the hotel guests. The dimensions are 22 x 6 x 1.5 meters.



*Rome Cavalieri Waldorf Astoria Hotel,
Rome (Italy)*

In the center of Rome, in an area nestled in the quiet, the Hotel offers a private park in which Myrtha Pools has built an elegant freeform pool and also refurbished the reinforced concrete pool for children.



*Embassy Suite Hotel,
Honolulu, HI (USA)*

A few steps from Waikiki beach, the hotel has spacious sundeck on the 4th floor roof including an impressive freeform Myrtha pool, heated and finished with elegant ceramic tiles.



*Hotel Landmark Mandarin Oriental,
Hong Kong*

Inside one the most outstanding luxury hotels in Far East, Myrtha Pools has built an indoor state-of-the-art 20 m lap pool, included in the facilities of the hotel fitness center.



Health and fitness clubs pools



La Alhondiga, Bilbao (Spain)

Myrtha builds dynamic facilities that allow for lap swimming, competition and aerobics for all levels of physical fitness and recreation. The streamlined look and high design of a Myrtha Pool compliments the prestigious property value of quality health clubs. Furthermore, Myrtha Technology pairs visible outer quality with unmatched inner structure and patented

technology for the most exacting pools and accessories in the nation. Once built, a Myrtha Pool will not require the same expensive maintenance needed by traditional pools. This guarantees that scarce resources will not be spent on capital expenditures and that any health club and its patrons will benefit from Myrtha Technology for years to come.

*Virgin Active Fitness Center Kennedy,
Milan (Italy)*

The versatility of Myrtha has been chosen for many Virgin Active Fitness Centers all around the world. In Milan, the Kennedy center has three Myrtha pools inside: a 22m pool with a RenovAction side, an hydromassage pool and a baby pool.



*Bellevue Club,
Bellevue, Washington (USA)*

Bellevue Club is one of the most exclusive and prestigious clubs in Washington area. The hotel Natatorium has been totally renovated and completed with high-level finishes and Myrtha Pools has been chosen for the construction of two new pools, designed and produced with outstanding mosaic glass tiles.



*Club Natació Catalunya,
Barcelona (Spain)*

Inside one of the oldest and prestigious Sports Centers in Barcelona, Myrtha Pools has installed a 25m competition pool, a 16 m learner pool and two SPA pools.



*Kirkby Leisure Center,
Kirkby (UK)*

Set in the middle of the town, the Leisure Centre contains a 25m competition pool and a 13 m learner pool, both constructed using Myrtha technology.



Thermal and SPA pools



Aquagranda thermal complex, Livigno (Italy)

Myrtha Pools have promoted their experience and their technologies, at international level, also in the thermal wellness sector, realizing exclusive projects, in centres often sited in areas rich in thermal springs, renowned to offer the real thing concerning anything to do with solutions and treatments for health. The quality of the materials used, specifically designed for the use in the swimming pool, allows for the maximum resistance to any type of water, from the one treated with chlorine, to the thermal and salty ones. Besides, the features of Myrtha Technology allow for the maximum versatility of the projects, that in many of these cases prove themselves to be highly

complex.

Communicating pools, partially indoor and partially outdoor, or placed on different levels and linked by waterfalls, hydromassage areas, rivers and lagoons. These are the different planning possibilities offered by Myrtha Pools for wellness and health, integrated furthermore by a complete series of indispensable accessories, such as hydromassage lounges, benches and islands, geysers, multicolour underwater lights. With special attention, finally, for details and finishes, often made in local stone, chosen to match with the natural characteristics of the surrounding environment.

Naturtherme Gesundbrunnen, Neuruppin (Germany)

In this modern Spa-Hotel, Myrtha technology has been applied to create a great impact on the environment and offer guests the pleasure center to swim admiring the surrounding landscape. Wellness, activity, leisure and Kneipp indoor and outdoor swimming pools have been placed at different levels inside the Center.



Grimming Therme, Bad Mitterndorf (Austria)

Grimming Therme is located within the fantastic alpine landscape of the Ausseerland area. The center offers a large thermal, relax and family area, in which Myrtha Pools has built seven indoor and outdoor thermal pools, finished with precious Bisazza glass mosaic and equipped with hydromassage benches and beds.



World Tauern Spa, Kaprun (Austria)

The brand new hotel and wellness centre has, besides rooms, gyms, shops, restaurants ecc., also many indoor and outdoor water areas. All the water surfaces has been built by Myrtha Pools, that used both overflow and skimmer system with the innovation of carbon's profiles and recessed overflow gutter.



Die Wörgl Wasserwelt, Wörgl (Austria)

Myrtha Pools has provided this state-of-the-art thermal center with all its aquatic facilities: two indoor pools, one competition and one leisure pool; one wide outdoor leisure and hydrotherapy pool; two indoor leisure pool connected with other two outdoor facilities by a corridor.

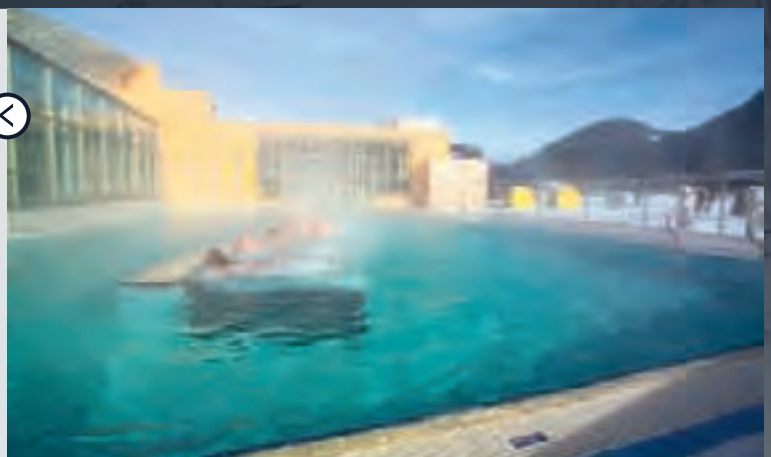

Institutional pools



Franklin High School, Indiana (USA)

Myrtha Pools have constructed some of the most highly acclaimed competition pools in the world. This same exacting precision and technology can be enjoyed in Universities, Colleges and Academic institutions all over the world. In USA Myrtha Pools has installations in YMCA cities and towns across

the country where they are enjoying the many benefits that Myrtha Pools offers.

Institutions receive state-of-art technology adding value to any campus. A sound choice for the allocation of resources, Myrtha Pools need no additional investment or capital expenditures for years to come.

Spire Institute, Geneva OH (USA)

SPIRE Institute is one of the largest indoor, multi-sport, training and competition complexes in the world. Spire is the home to two Myrtha Pools. The main competition 54 m pool is the only true Olympic sized pool in the region. The pool has Myrtha's state of the art track-start starting blocks and two flow-through moveable bulkheads.

The second Myrtha Pool at Spire is a 6-lane warm up and teaching pool.

A 25-yard recreation/warm-up pool with a long wheelchair ramp is completed in an adjoining, but separate room.

Still under construction are four therapy pools.



New Tampa YMCA, Tampa, FL (USA)

Built in 2001, Tampa YMCA aquatics facility consists of a 25 yard by 50 meter Myrtha overflow pool. This set up allows the teams to utilize both short course and long course training and has allowed for this location to become an epicenter for competitive swimming. The pool is actually the home for local and regional competition, high school swim teams and meets, college teams from throughout the country, and international swim teams.



Trent University Rowing Center, Peterborough, ON (Canada)

Myrtha Pools has provided the first rowing tanks in Canada for Trent University. The Trent University Rowing Crew, as well as community groups, will be training through the winters on their Myrtha Rowing Tanks. Capable of accommodating 8 rowers and 16 dragon boat paddlers, the tanks were developed as part of a major expansion of the Trent University Fitness facilities.



University of East Anglia, Norwich (UK)

The University campus offers a wide variety of options for taking part in sports, among which a 51 m indoor competition pool, equipped with bulkhead and movable floor.



Therapy and rehabilitation pools



Don Ronchi Rehabilitation Center, Brescia (Italy)

The perfectly self-supporting structure of Myrtha Technology is ideal in these cases because it allows for the insertion of the pool in pre-existent rooms, often narrow or hardly accessible, and it allows furthermore the construction of the pools also completely above ground. This facilitates the operators and the medical staff in the carrying out of their own job around the pool and it allows them to monitor more comfortably the activities both through the deck and through special windows placed along the walls of the pool.

Myrtha Therapy supplies also all the range of accessories indispensable for the therapy: floor partitions and wall ergonomic handrails, floors at different levels for progressive or differentiated therapies, hydro-massages with inlets at different heights, adjustable in flow and direction, blow benches, external paths for the assistance to the activities by the appointed staff, lifting tackles for disabled, underwater windows and windowed walls for the monitoring of the activity in the pool.

*Milan Football Club Physiotherapeutic Center,
Milan (Italy)*

All the three pools of the Center, that hosts Milan FC athletes, have been made with Myrtha Technology. There are equipped with various types of accessories for different therapies: benches, beds and sitting height variable structures made with stainless steel, corridors for hydrotherapy, heating and cooling water.



*Acibadem Fulya Rehabilitation Center,
Istanbul (Turkey)*

The Acibadem Fulya Sports Medicine Center consists of internationally renowned medical and surgical facilities in the fields of orthopedics and sportsmen's health. Among which a new Myrtha physiotherapeutic pool, fully equipped with solution for rehabilitation.



*Stefani Foundation,
Vicenza (Italy)*

One of the most important Foundations for disabled people rehabilitation hosts in its Physiotherapeutic Center two Myrta therapic pools.



*CTO – Orthopaedic Trauma Center,
Florence (Italy)*

The Orthopedic Trauma Center of Florence (CTO) is one of the first specialized hospitals built in Italy during II World War. In recent years it has been subjected to a renovation project, that includes the installation of two Myrtha physiotherapeutic pools.



Temporary pools



Waterpolo Arena, 2012 Olympic Games, London

Nowadays, with world level competitions requiring seating for crowds of 10,000 plus, the installation of a permanent pool is not possible, especially indoors. The Myrtha Evolution Technology has been specifically designed to meet the need for such “special events”.

Myrtha Evolution not only allows us to obtain a pool with dimensions and features suitable for such high

level events, but is also enables the installation of swimming pools inside stadiums or sports halls, without need to drill the floor and offering to the world of swimming the opportunity to transform these competitions into unforgettable shows. In all these cases, furthermore, once finished the sporting event, the pool is disassembled and re-installed permanently elsewhere.

*Omaha 2012.
U. S. Olympic Trials, USA*

Myrtha Pools installs two 50 meter temporary pools for U.S. Olympic Team Trials – Swimming. The state-of-the-art CenturyLink Center in Omaha turns into a world-class swimming arena. After the Trials closing, both pools have moved to new, permanent homes.

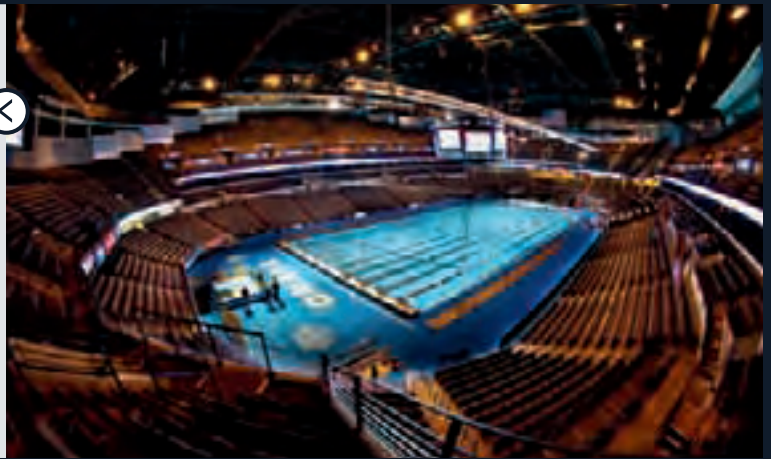

*Shanghai 2011.
14th FINA World Championships*

Myrtha Pools supplies two temporary pools installed in the Oriental Sports Center, a few weeks before the event, and then dismantled at the end of championship.



*Rome 2009.
13th FINA World Championships*

The event was held on the tennis courts of the Foro Italico by using two temporary pools supplied by Myrtha Pools: one water polo and one synchronized swimming pool, both used for competitions.



*Rio de Janeiro 1995.
2nd FINA World Championships (25 m)*

Myrtha Pools installes two 25 m temporary pools, a competition and a warm-up pool, on the famous Copacabana beach.



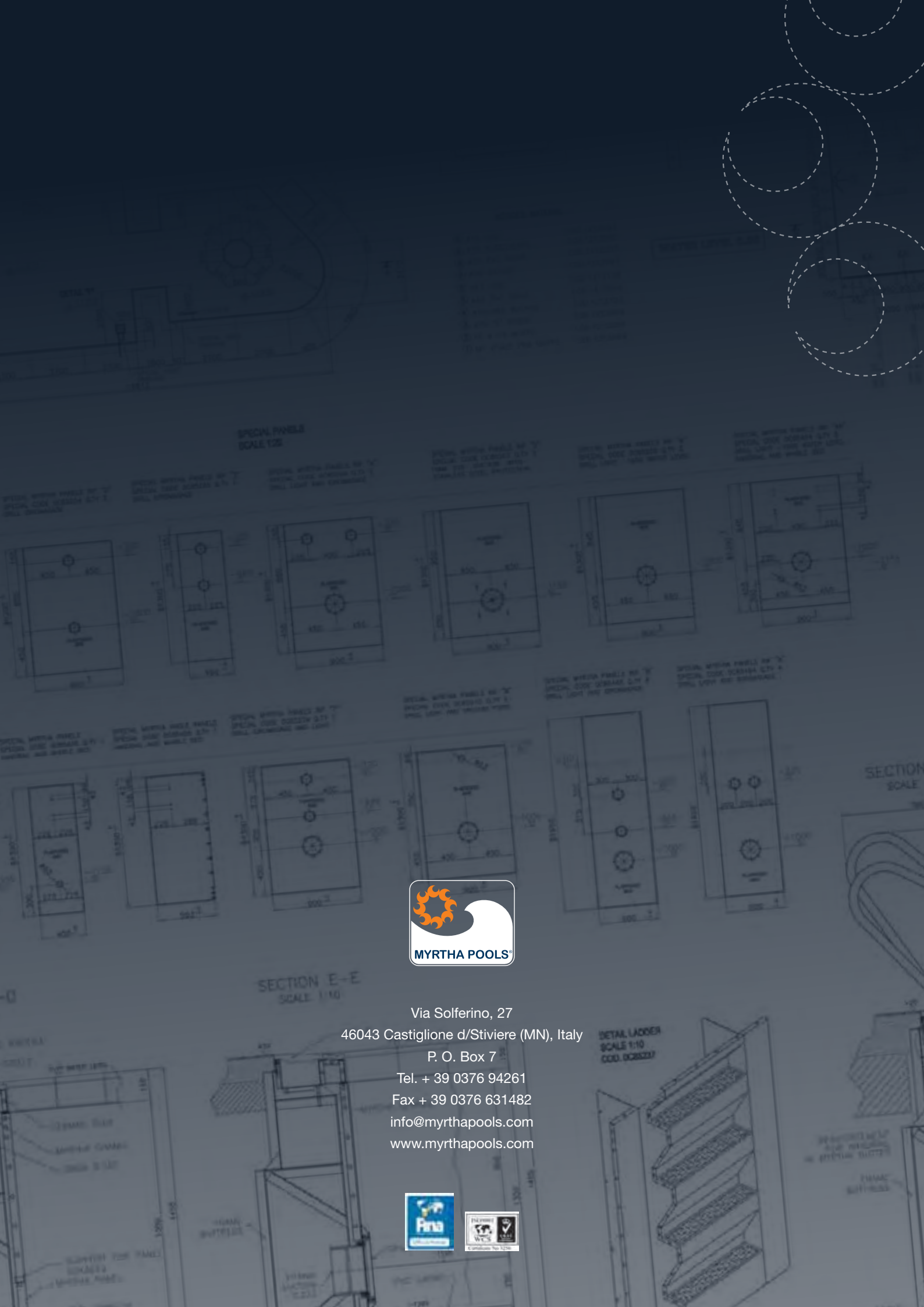

Via Solferino, 27
46043 Castiglione d/Stiviere (MN), Italy
P. O. Box 7
Tel. + 39 0376 94261
Fax + 39 0376 631482
info@myrthapools.com
www.myrthapools.com

